

# Applications of Laser Ablation to Microengineering

Malcolm Gower and Nadeem Rizvi

Exitech Limited

Hanborough Park, Long Hanborough, Oxford OX8 8LH, United Kingdom

## ABSTRACT

Applications of pulsed laser ablation to the manufacture of micro-electro-mechanical systems (MEMS) and micro-opto-electro-mechanical systems (MOEMS) devices are presented. Laser ablative processes used to manufacture a variety of microsystems technology (MST) components in the computer peripheral, sensing and biomedical industries are described together with a view of some future developments.

**Keywords:** Pulsed lasers, laser ablation, microengineering, MST, MEMS, sensors, nozzles, lab-on-a-chip.

## 1. INTRODUCTION

Microsystems technology (MST) is still in its infancy compared to other well-established fabrication techniques yet it has already penetrated the market for a wide range of products, including display devices, printers, read-write heads for computer hard disks, medical and biomedical systems, telecommunications systems and a variety of sensors in the aerospace and automotive sectors.

Recent surveys have predicted astonishing growth rates for MST devices where the total market share for MST products is estimated to be worth many tens of billions of dollars within a couple of years. A NEXUS report [1], for example, forecast an annual growth rate of 20% for MST technologies. The impact of MST systems on society is likely to be all-pervasive but cannot be accurately forecast at present since the range of technologies is so vast and covers mechanical, optical, electrical, chemical and medical functions.

The mass-market take-up of MST devices has so far been limited due to a number of factors, not least because the manufacturing routes for production have not been fully developed. One of the avenues being explored actively is the use of lasers for the production of MST-related systems. Lasers complement conventional silicon-based microtechnology in many sectors but also offer totally new options in terms of the structures, materials and processes which can be accessed. Some of the recent developments in laser micromachining which relate to MST devices are presented in this article.

## 2. LASER MICROMACHINING

All laser micromachining techniques use the process of laser ablation, where the interaction of the laser energy with the sample leads to material removal. Laser ablation usually relies on the strong absorption of laser photons by the sample material which means that the wavelength of the laser has to be chosen carefully for maximum absorption. The use of ultrafast lasers, however, has circumvented this approach since ablation takes place as a result of multi-photon absorption at high peak intensities, which means that even materials normally transparent to the laser wavelength can be machined.

The following sections deal briefly with some of the lasers used in high-resolution micromachining applications and the associated techniques that are employed with them.

## 2.1 Lasers

The types of lasers currently being used for micromachining applications include carbon dioxide lasers, solid-state lasers (e.g. Nd:YAG and titanium sapphire), copper vapour lasers, diode lasers and excimer lasers. These laser systems are continually being developed and this improved laser performance is also helping in the rapid progress being made in the laser manufacturing of MST components. The work described in this article was performed using an excimer laser ( $\lambda=248\text{nm}$ ), a fundamental Nd:YAG laser ( $\lambda=1064\text{nm}$ ), a frequency-tripled Nd:YAG laser ( $\lambda=355\text{nm}$ ) and a Ti:sapphire laser ( $\lambda\sim 800\text{nm}$ ). These lasers, and the micromachining techniques used with them, encompass some of the most interesting developments taking place in the MST field currently.

Pulsed solid-state lasers are becoming increasingly attractive in microengineering industries since they can offer:

- Wide choice of wavelengths (either through direct tunability or via harmonic generation)
- A variety of temporal pulse widths (ranging from milliseconds to a few femtoseconds)
- High pulse repetition rates (from tens to hundreds of kilohertz)
- Large choice of output powers
- Excellent "wall-plug" efficiencies (especially with diode-pumped systems)
- Compact sizes
- Economically-favourable running costs

Although excimer lasers cannot compete with the solid-state lasers directly on the above grounds, the maturity, flexibility and types of microstructuring offered by the short wavelengths produced by excimer lasers mean that they continue to be used for innovative applications in many diverse industrial sectors.

## 2.2 Micromachining Techniques

The main difference between excimer lasers and the solid-state lasers mentioned above is in the beam propagation characteristics. The excimer laser has a highly divergent output where the beam is (spatially) multimode in nature. By contrast, the Nd:YAG and Ti:sapphire lasers emit beams which have a Gaussian  $\text{TEM}_{00}$  intensity profile and so are highly spatially coherent.

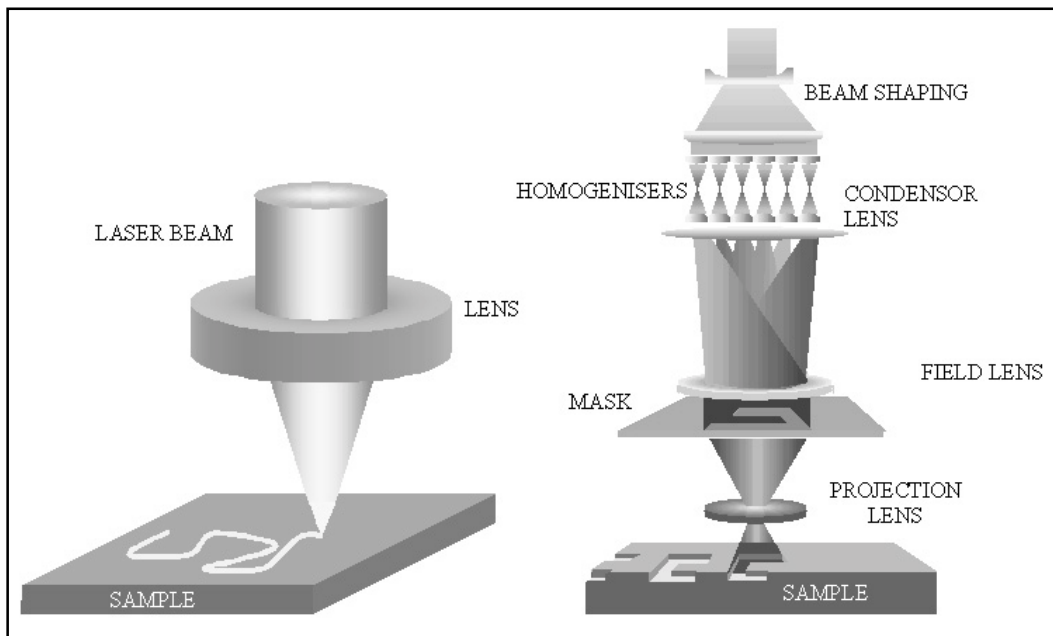

Figure 1. Representation of (a) direct writing and (b) mask projection.

As a result, the beams from the solid-state lasers can be focused directly to very small spot sizes whereas the beams from excimer lasers are generally not focussed for the majority of applications (especially since the beam is normally rectangular in shape with different divergences in orthogonal directions). Excimer laser beams, being multimode and spatially incoherent, are ideally suited to mask projection, as described below.

The basic concepts of direct focussing (or direct writing) method and mask projection are shown in figure 1.

The details of direct writing [2] and mask projection [3] have been presented previously but their respective merits and drawbacks can be summarised as in table 1.

| DIRECT WRITING |   | MASK PROJECTION   |
|----------------|---|---|
| Advantages     | Simple technique  | Very flexible technique   |
|                | Optics are usually simple and inexpensive                   | Many types of structures can be produced with the same system                                   |
|                | Only sample or beam motion is required                      |   |
|                | Can interface with CAD data files for complex patterning    | Can use the short wavelengths of excimer lasers to machine with very high precision and quality |
|                |   | Mask projection can mimic direct writing technique by projecting circular aperture.             |
|                | Can use lasers which run at very high repetition rates      | Can machine relatively large areas (100s mm <sup>2</sup> ) at a time                            |
| Problems       | Can be used for serial writing rapid prototyping of devices | Can be used for batch processing of volume products   |
|                | Limited range of features which can be produced             | Projection optics can be expensive  |
|                | Only a small area can be machined at a time.                | Excimer lasers operate at modest repetition rates   |
|                |   | Needs manufacture of masks  |

Table 1. Comparison of direct writing method with mask projection technique.

The basic direct writing method is now in widespread use in the automotive and aerospace areas for the cutting or welding of parts, for example, but this cannot strictly be considered to be an MST application even though the final products (e.g. cars) may contain dozens of MST components. There are other applications being developed which illustrate the use of these two methods in MST sectors more clearly and these are presented in the following sections.

### 3. APPLICATIONS OF LASER MICROPROCESSING

Laser micromachining techniques have been developed to a stage now that more than one processing method is often suitable for any particular job. This is a desirable situation as it permits the MST device designer to choose the optimum route for production, unhindered by technical constraints. It is now common, for example, to machine parts of a device with one technique and then add further component structures with a different method – the so-called “mix and match” approach.

#### 3.1 Nozzles

The production of nozzles, of whatever shape or form, is now a huge market with sales expected to be in the region of ~\$600M per year. This sector covers many areas from printing, computing and medicine - microfluidics, in general. All parts have, however, benefited from the high performance devices made possible by laser micromachining.

The majority of ink-jet printer nozzles are currently drilled using excimer lasers and mask projection methods. Mask projection is ideally suited to this application because:

- The nozzles are made in polyimide tape, which is machined very well at UV wavelengths.

- Mask projection allows the entire nozzle head (with a couple of hundred holes) to be drilled at the same time by projecting the whole layout.
- The reproducibility of the excimer laser process is excellent, allowing a typical hole diameter tolerance of  $\pm 1\mu\text{m}$  to be achieved in volume production.

Figure 2 shows a section from typical printer nozzle head which has been machined using an excimer laser. The holes are usually of the order of  $\sim 25\mu\text{m}$  and the quality and uniformity of the holes are clearly evident.

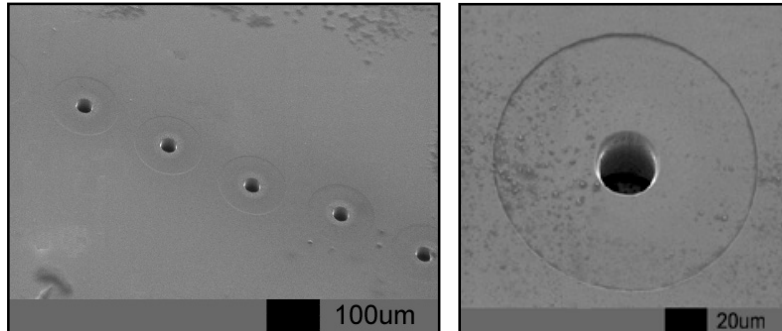

Figure 2. Ink-jet printer nozzles drilled using excimer laser mask projection.

It should be noted that direct write and mask projection techniques are, to some degrees, interchangeable. A direct write set-up (where a lens is used to focus a laser beam onto a sample) can be adapted simply to work in projection mode by the placement of a suitable mask upstream of the lens. The sample can then be machined at the image plane of the lens (which is different from the focal plane). Similarly, a mask projection system can mimic a direct write tool by using a circular mask, and using the projected spot in the same way as a focussed beam.

The hole dimensions, the cross-sectional profile and additional features around the holes all need to be controlled and mask projection allows this to be achieved. The flexibility of projection methods means that more than one shape can be superimposed on the sample to achieve multiple shapes. An example of some nozzle holes with a surrounding reservoir structure are shown in figure 3. This was machined in polyimide by using two separate masks and positioning them on top of one another.

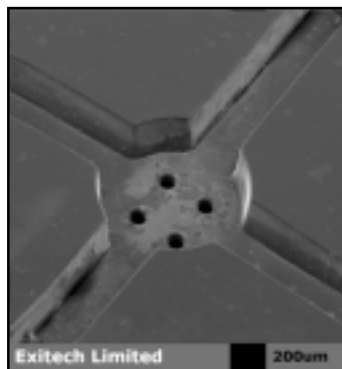

Figure 3. Nozzles machined in polyimide using multiple mask projection.

Another crucial element in microfluidic applications is the cross-section of the nozzle and this can also be controlled using mask projection techniques. Either convex or concave profiles are possible, as shown in figure 4.

Although the drilling of ink-jet nozzles is now a routine operation with excimer lasers, it is interesting to investigate other options which may allow different results. We have used a frequency-tripled Nd:YAG laser ( $\lambda=355\text{nm}$ ) and direct writing to drill nozzle holes with an inverse taper angle, i.e. where the entrance hole size is smaller than the exit hole diameter. A high numerical aperture visible objective lens (x40, NA=0.45) was used in conjunction with a circular aperture so that the lens projected the image of the aperture on the sample.

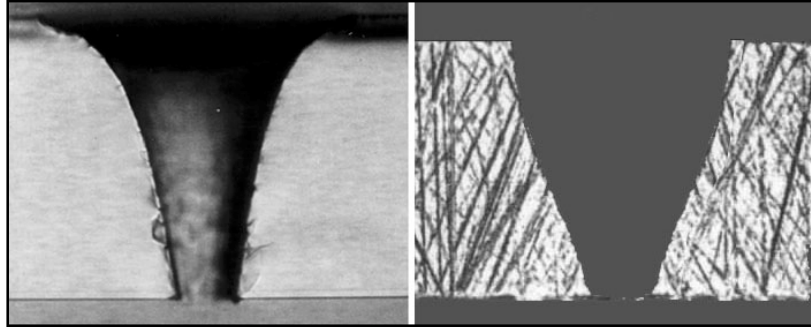

Figure 4. Shaped nozzle cross-sections in glass (left) and polycarbonate (right) drilled using excimer lasers.

Percussion drilling of a 75 $\mu\text{m}$  thick polyimide sample was optimised in terms of laser power at a laser repetition rate of 1kHz. At a laser energy density of 7J/cm<sup>2</sup> and 200 laser shots, a full taper angle of  $\sim 30^\circ$  was achieved. The laser repetition rate was 1kHz which corresponds to 0.2sec per hole. Figure 5 shows a photograph of three inverse taper holes drilled in polyimide as viewed from the exit side. It was not possible to carry out this drilling at higher pulse repetition rates due to technical limitations on the laser but there should be no issue with this machining being performed at many tens of kilohertz in the future.

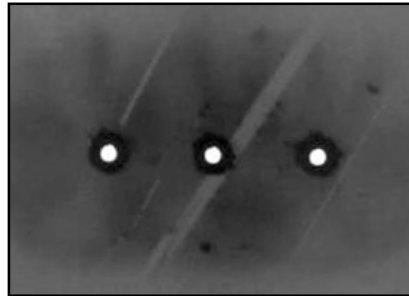

Figure 5. Inverse taper holes drilled at 355nm.

This type of nozzle drilling is of interest for the in-situ drilling of ink-jet printer heads where the print head is assembled before the nozzle holes are drilled. This obviously has advantages in that the alignment of pre-drilled holes to the print head is avoided but it does require the holes to have an inverse taper.

Such inverse taper nozzles have been drilled with excimer laser mask projection systems previously but this method with a solid-state laser appears to offer the added benefits of high repetition rates and efficient laser sources. Further work is in preparation for extension of this technique to 266nm and to assess the issues of the simultaneous drilling of multiple holes and a quantification of the parameters required for the generation of specific taper angles.

### 3.2 Display Devices

There has been intense research into various types of display devices in recent years and different types of flat-panel displays (FPD) are set to supersede conventional cathode-ray tubes (CRTs) soon in most high-definition and large area applications. The total display market is expected to be around \$30 billion within a couple of years [4].

As the demand for ever-larger panels grows, conventional methods of production based on photolithography and etching become problematic and expensive. Hence, lasers are finding increasing use in the processing of various types of FPD, including laser annealing of silicon and patterning of the constituent layers of the panel with electrode structures. In addition, there is also research in the patterning of optical structures on display devices for the control and manipulation of light to enhance visibility. This is also being achieved using laser micromachining.

Figure 6 shows a layer of indium tin oxide (ITO) which has been laser machined using a third harmonic Nd:YAG laser ( $\lambda=355\text{nm}$ ) in direct write mode. The width of the individual tracks is  $25\mu\text{m}$  and the sample was moved under CNC control to define the electrode structures.

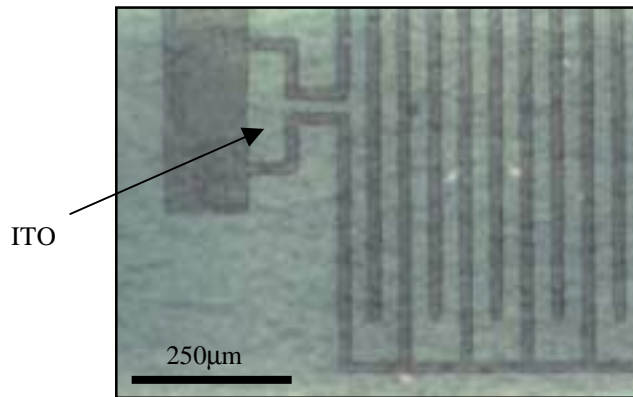

Figure 6. ITO layer on glass patterned with 355nm Nd:YAG laser.

The method of direct writing of the electrodes has the following advantages:

- The size of the panels is only limited by the XY tables on the laser patterning machine
- Very high repetition rate lasers can be used
- The definition of the pattern is computer controlled and so is very flexible. No mask is required.
- It is a single-stage dry process.

The direct writing technique can be expanded to include beam scanning optics, thereby increasing the speed of processing and area of coverage. It is normal in beam scanning systems that the area in one scan field (which is typically 50-100mm square) is machined and the sample is then moved in XY to allow the adjacent pattern area to be “stitched” onto the first pattern. This not only requires a high degree of control in the stitching accuracy but also reduces the speed of processing as the laser is turned off while the sample is moving in between the adjacent sites. We have refined the scanning technique further by having the sample moving continuously while the beam is scanned over it. This can only work if the data for the scan field is constantly updated and synchronised with the position of the sample and we have achieved this by the use of sophisticated digital signal processing [5]. This technique is called *Sync Scan*<sup>TM</sup>.

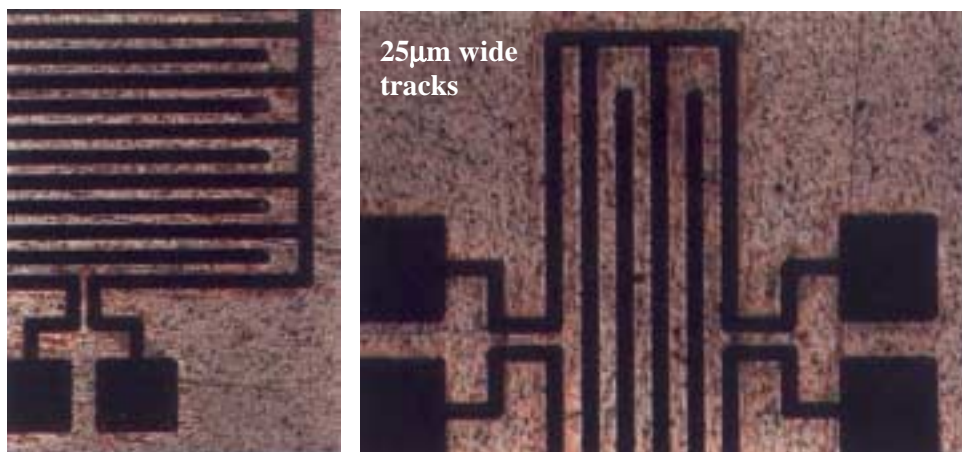

Figure 7. Circuit patterns ablated into polyimide (on copper substrate) by 3<sup>rd</sup> harmonic Nd:YAG laser.

The same laser system which was used for the writing of the ITO patterns was used for the selective removal of polyimide from a copper substrate. In this approach, rapid prototyping of devices can be carried out either by directly electro-forming up from the exposed metal layer or by using the metal part as a replication master. In the samples shown in figure 7, a simple

circuit design was machined into the polyimide for demonstration purposes. The laser wavelength was 355nm and a fluence of  $0.6\text{J}/\text{cm}^2$  was used with 5 shots per area to write the tracks. The widths of the tracks are  $25\mu\text{m}$ .

Many sensor applications require the patterning of a variety of materials or the removal of metallic layers for isolation purposes. Direct laser writing with high repetition rate lasers is a very efficient method of achieving this and so should find use in many sensing sectors.

### 3.3 Biomedical Chips

Advances made recently in personal healthcare and environmental monitoring have led to the development of various diagnostic devices which perform different analysis functions. The applications of these diagnostic “chips” is widespread, including food and water supplies, drug delivery systems, personal drug administration, DNA analysis, blood monitoring etc. One of the most researched areas has been the so-called biofactory-on-a-chip, with this term encompassing any compact, discrete device used for a micro-monitoring or analysis operation (in any chemical, environmental or medical field).

Although the silicon-based sensor devices are extremely advanced and mature, their inherent bio-incompatibility means that other materials have been explored. Many of these bio-degradable or compound materials are not well-suited to conventional etching processing and so laser machining of these devices is becoming ever more important.

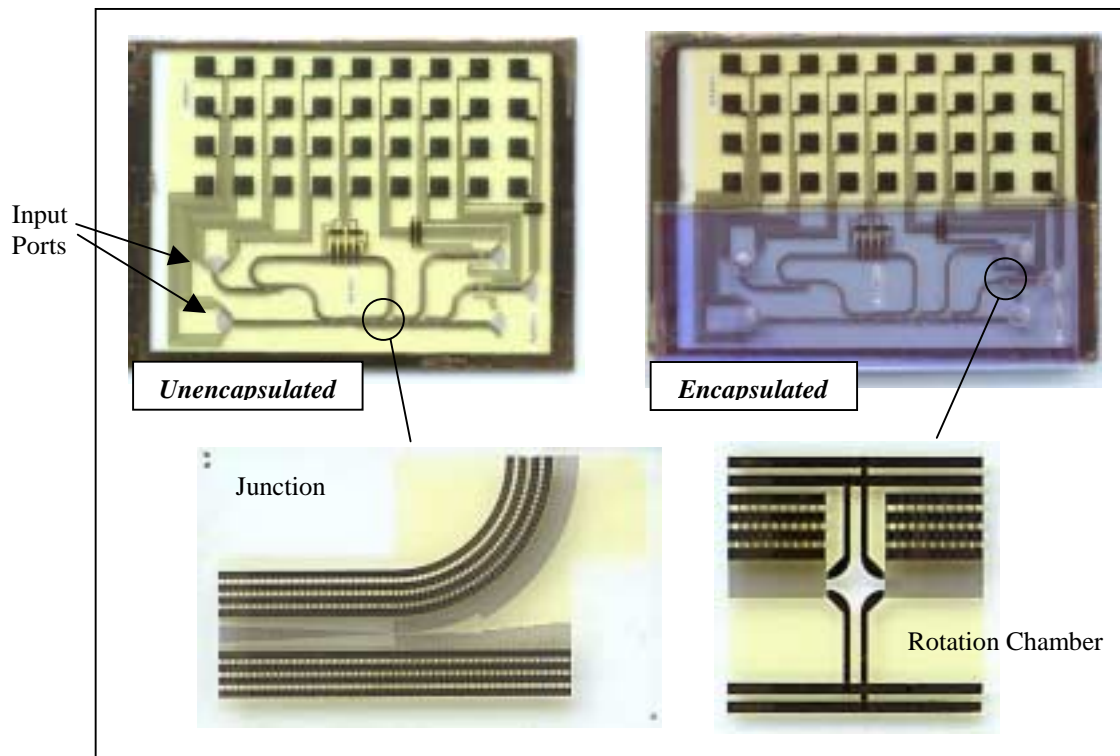

Figure 8. Biochip manufactured using laser micromachining.

A biochip manufactured using laser technology is shown in figure 8. This device was developed by Pethig and co-workers at the University of Wales Bangor and consists of a multi-level layout of gold electrodes and insulating polymers. The process of manufacture has been presented elsewhere [6] but in general, an excimer laser is used to ablate a gold layer to leave behind  $10\mu\text{m}$  wide electrodes and is also used to machine interconnect via holes in a polymer. Microchannels are machined to transport the sample from the inlet ports to the analysis sites. The basic control of the sample fluidics is performed by dielectrophoresis and the whole chip is controlled by a low voltage power supply. The chip is connected to external power and optical recognition devices and the overall dimension of the substrate is  $55\text{mm} \times 40\text{mm}$ .

The advantages of using a laser-based micromachining method are that all the process steps can be carried out on the same machine, there is no wet etching involved and there is great flexibility in the design of the chip layout. Further work is underway to characterise more fully the operation of the chip, to look at miniaturisation issues and to design further chips for other functions.

### 3.4 Diamond Micromachining

Diamond is a unique material and has a set of mechanical, thermal and optoelectrical properties which are unrivalled. Synthetic chemical-vapour deposited (CVD) diamond is now available in high quality, large size samples and so the usage of CVD diamond is increasing, especially for optical applications. Areas of interest include windows or optical components for high power lasers (e.g. CO<sub>2</sub> lasers) and the use of CVD diamond for sensing applications in the deep UV. In both cases, the rough nature of as-grown CVD diamond needs to be modified to make useful devices.

Normal CVD diamond has a faceted structure where the peak-to-valley variations can be as large as 20-50µm in height. In optical applications, this means that the structure has to be removed to obtain a better surface profile; in sensor applications, the surface needs to be smooth to allow electrodes to be put down for electronic structures. In both cases, the surface smoothing can be obtained with excimer lasers [7].

Figure 9(a) shows CVD diamond which has been smoothed using an excimer laser at 248nm and a fluence of 25J/cm<sup>2</sup>. This smoothing was done at an incidence angle of 45°. The number of shots per area determines the extent of smoothing, as can be seen from the right-hand and left-hand bands in figure 9(a). Although the quality of the laser smoothing using excimer lasers is very good, there is an inherent problem in that surrounding areas tend to suffer from graphitisation effects, which are generally undesirable.

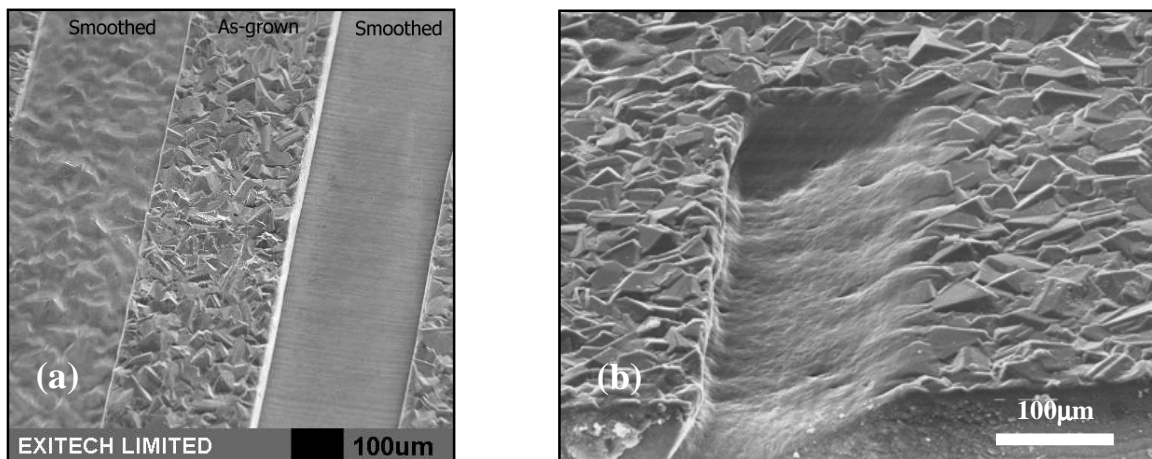

Figure 9. Laser smoothing of CVD diamond using  
(a) an excimer laser at 248nm and (b) a femtosecond Ti:sapphire laser at 800nm.

An option which is being investigated at the moment is the machining of CVD diamond using ultrashort laser pulses from solid-state lasers such as Ti:sapphire or Nd:YAG lasers. Figure 9(b) shows preliminary work on the assessment of laser smoothing using a femtosecond Ti:sapphire laser. This sample was also processed at an incidence angle of 45° with a laser wavelength of 800nm, a pulse duration of 150fsec and an incident fluence on the sample of 10J/cm<sup>2</sup>. The Ti:sapphire laser beam was focussed down to a spot of ~15µm and then the smoothing was performed using direct writing. The smoothing seen in figure 9(b) was obtained with ~110 shots/area. Using ultrashort pulses, however, does give the important benefit of no graphitisation of the machined or surrounding areas.

CVD diamond machines extremely well with high intensity, ultrashort pulses and these lasers may replace excimer lasers for some diamond machining applications [8].

#### **4. FUTURE DEVELOPMENTS**

It seems clear that lasers will become the micromachining tools of choice for manufacturing MST, MEMS and MOEMS devices in many emerging applications. In some areas such as microfluidic systems or micro-mechanical devices, laser micromachining is likely to be used for the manufacture of masters after which mass production will be accomplished by replication techniques. A wider variety of lasers are likely to come into manufacturing environments – different wavelengths from deep UV (157nm) to IR (10µm), pulse durations from microseconds to femtoseconds – and diode-pumped solid-state lasers could bring about a hitherto unrealised era of extremely efficient and compact laser tools. More mixing of complementary techniques (e.g. chemical or plasma etching coupled to laser) is also likely to be used where materials and functions from various processes are used

#### **5. SUMMARY**

A range of laser micromachining applications have been described which use high-resolution laser micromachining techniques using different lasers. The techniques of direct writing and mask projection have been described and their use in various applications have been detailed.

#### **6. ACKNOWLEDGEMENTS**

The authors wish to thank the following people for their helpful contributions: Thorsten Bauer of Laser Zentrum Hannover in Germany for the use of the Ti:sapphire laser in the machining of the diamond samples; Mark Talary of the University of Wales Bangor for some of the SEM pictures presented and for the provision of the photographs of the Biofactory-on-a-Chip; Philip Gruenewald of Exitech for some of the micromachining demonstrations. Part of this work was conducted as part of the UK BBSRC-funded project “Development of Biofactory on a Chip Technology” (#5/TO6337) and DTI LINK “INDDUV” project.

#### **7. REFERENCES**

- [1] “Market Analysis for Microsystems 1996-2002” NEXUS report (1998)
- [2] “Microengineering applications of pulsed lasers” Nadeem Rizvi, Proceedings of Microengineering '99 – Congress for Microsystems and Precision Engineering, pp161-168, Stuttgart, Germany (1999).
- [3] “Production of novel 3D microstructures using excimer laser mask projection techniques” Nadeem Rizvi, Symposium on Design Test and Microfabrication of MEMS and MOEMS, pp546-552, SPIE vol. 3680, Paris, France (1999).
- [4] “Europe on display” Cordelia Sealy, European Semiconductor, pp25-27 (June 1999).
- [5] “Developments in laser micromachining techniques” Nadeem Rizvi and Paul Apte, ICOPE 2000 Conference, Singapore (March 2000).
- [6] “Development of Biofactory on a chip technology using excimer laser micromachining” R. Pethig, J.P.H. Burt, A. Parton, N.H. Rizvi, M.S. Talary and J. A. Tame, J. Micromech. Microeng., vol. 8, pp57-63 (1999)
- [7] V.G. Ralchenko and S.M. Pimenov, Diamond Films & Tech. Vol. 7 (1997)
- [8] “Laser Micromachining - New Developments and Applications” Nadeem Rizvi, David Milne, Phil Rumsby and Malcolm Gower, Photonics West, Santa Clara (January 2000).

Correspondence: e-mail: m.gower@exitech.co.uk; Tel: +44 1993 883324; Fax: +44 1993 883334